

word root sect means cut

perimeter

trees

ardent

munched

isolate

trapezoid

desire

ornament

playful

faithful

above

enthusiastic

garment

Word Study

hopeful

whose

Week of _____

fever

scarecrow

ailment

exuberant

posterior

word root post means after

mechanics

wonderful

posterity

fifth

intersect

dissect

intersection

challenging

My Name: _____

Your Words

Pick 1 to do:

- page 1
- pages 2-3
- page 4

Math Break

Pick 1 to do:

- page 7
- page 8
- page 9
- page 10
- page 11

Spelling Workout

Pick 9 to do:

- page 12
- page 13
- page 14
- page 15
- page 16
- page 17
- page 18
- page 19
- page 20
- page 21
- page 22

Spelling Break

Pick 1 to do:

- page 23
- page 24
- page 25

CH Words

Pick 2 to do:

- page 27
- page 28
- page 29

Vocabulary

Do all of these:

- page 5
- page 6

Challenge Words

Do this:

- page 26

Name: _____



posterity • fifth • scarecrow • whose • isolate • challenging • faithful
 enthusiastic • fever • desire • trapezoid • ailment • trees • exuberant
 mechanics • detest • hopeful • munched • above • dissect • ardent
 ornament • perimeter • garment • intersect • intersection • wonderful
 playful • hunched • posterior

Write four words that you are unable to define.

Write ten of the most difficult words to spell.

Write ten words that you have not yet written.

Name: _____

Picture Dictionary

Draw a picture of 11 of your words. Write the word in cursive.



EXAMPLE. laughed

1. _____

2. _____

3. _____

4. _____

5. _____

Name: _____

6. _____

7. _____

8. _____

9. _____

10. _____

11. _____

Name: _____

S T F I G A G S E H S A G Z L
 S R E H T O M D N A R G N A R
 D R E G G E T G A T E S T S G
 R N G A F S N M G A M E M E D
 S A N I L G F G L U E M A E G
 E N S G R O W N W G G R L N E
 E T M S O J G G A E L S H G E
 N S F R N E V I G L A A N E S
 O G O A L G G U Q G S E S E E
 G A E N H G G A N E S S O G L
 G S S G A L L O N S H H N H E
 E G O I N G G A E R E L S I E
 S R F A G I R A F F E S M I U

"G" Words

G _____ G _____
 G _____ G _____
 G _____ G _____
 G _____ G _____
 G _____ G _____
 G _____ G _____
 G _____ G _____
 G _____

I found _____ "G" words.

If $a = 12$, then what does $a - 7$ equal?

April bought a book about the night sky. She wanted to be able to find the pictures made by the stars. The book cost \$11.69. If she gave the clerk \$15, how much change did she get?

Fill in the boxes so each line equals 12.

12

$19 - \square$

$72 \div \square$

$\square \times 3$

$(19 - \square) + \square$

$2 + \square \times \square$



Name: _____

Word Roots to Know:

post

means after

posterior

posterity

sect

means cut

intersection

dissect

intersect

Vocabulary is confusing. Get to the root of the problem with word roots! Here are the answers:

dissect • intersect • cut • post • after • posterior • posterity

Word with	h r k i n t e r s e c t n j b y c z d
the root: sect	i n t e r s e c t n n e s s e c i t y

Word with	p r o s t e r i t y p o s t e r i t y
the root: post	d p o s t e r i t y p o s p e r i t y

The root: sect	u o e t a u c u t c u u t g t q t z u
means	u p k n c t k u h t j u t c u t u t u

This root	o n t t s g y p o s t m p p p o s t e
means after	o t s e p o s t s p a h s t i b s t v

Word with	s t s t f d i s s e c t d i s e c t n
the root: sect	e d o s s i c t d i s s e c t c t u i

Word with	t r r u w t t r p o s t e r i o r o e
the root: post	o o s p o s t e r i o r c p k r r r i

The root: post	z a f t i r a n q t b i s e a f t e r
means	a d a f t e r j l a t u r o m t r a k

Name: _____

GALE OWNER UNIVERSAL

ALUMINUM ANIMATE LEGACY

PORTER VOLUNTARY UTTER VISIBLE

SUBMERGE TREADMILL FAME ALLERGIC

FEATHER BANJO HUMAN DYNAMIC

WRANGLE TYPICAL

Circle the words that you know. I circled _____ words.

Use two of the words you know in a sentence.

Write five words that you don't know or want to know better.

Circle words to the RIGHT or DOWN. Every letter is used exactly ONCE.

A L U M I N U M H U M A N S F
O V D R U N I V E R S A L U O
A O O O A L L E R G I C B X
R L G C F D W R A N G L E M O
L U P K E Y N I N E F G E W
E N O B A N H E A V Y A A R N
G T R A T A Q U A R T M L G E
A A T N H M U T T E R E E E R
C R E J E I I S V I S I B L E
Y Y R O R C A M T Y P I C A L

Name: _____

$\frac{1}{2}$						$\frac{1}{2}$					
$\frac{1}{3}$				$\frac{1}{3}$				$\frac{1}{3}$			
$\frac{1}{5}$		$\frac{1}{5}$		$\frac{1}{5}$		$\frac{1}{5}$		$\frac{1}{5}$		$\frac{1}{5}$	
$\frac{1}{6}$		$\frac{1}{6}$		$\frac{1}{6}$		$\frac{1}{6}$		$\frac{1}{6}$		$\frac{1}{6}$	
$\frac{1}{7}$		$\frac{1}{7}$		$\frac{1}{7}$		$\frac{1}{7}$		$\frac{1}{7}$		$\frac{1}{7}$	
$\frac{1}{11}$	$\frac{1}{11}$	$\frac{1}{11}$	$\frac{1}{11}$	$\frac{1}{11}$	$\frac{1}{11}$	$\frac{1}{11}$	$\frac{1}{11}$	$\frac{1}{11}$	$\frac{1}{11}$	$\frac{1}{11}$	$\frac{1}{11}$
$\frac{1}{12}$	$\frac{1}{12}$	$\frac{1}{12}$	$\frac{1}{12}$	$\frac{1}{12}$	$\frac{1}{12}$	$\frac{1}{12}$	$\frac{1}{12}$	$\frac{1}{12}$	$\frac{1}{12}$	$\frac{1}{12}$	$\frac{1}{12}$

Compare.

$\frac{2}{6}$ ○ $\frac{1}{3}$	$\frac{1}{5}$ ○ $\frac{1}{2}$	$\frac{4}{7}$ ○ $\frac{1}{11}$	$\frac{4}{6}$ ○ $\frac{2}{5}$
$\frac{2}{3}$ ○ $\frac{2}{12}$	$\frac{10}{12}$ ○ $\frac{5}{6}$	$\frac{5}{7}$ ○ $\frac{2}{3}$	$\frac{1}{2}$ ○ $\frac{3}{11}$
$\frac{8}{12}$ ○ $\frac{2}{3}$	$\frac{1}{7}$ ○ $\frac{4}{5}$	$\frac{3}{7}$ ○ $\frac{6}{11}$	$\frac{1}{5}$ ○ $\frac{1}{6}$
$\frac{10}{12}$ ○ $\frac{1}{2}$	$\frac{2}{6}$ ○ $\frac{2}{3}$	$\frac{3}{6}$ ○ $\frac{1}{2}$	$\frac{5}{12}$ ○ $\frac{1}{2}$
$\frac{2}{3}$ ○ $\frac{2}{11}$	$\frac{10}{11}$ ○ $\frac{2}{12}$	$\frac{1}{3}$ ○ $\frac{4}{5}$	$\frac{2}{12}$ ○ $\frac{1}{6}$
$\frac{2}{3}$ ○ $\frac{6}{7}$	$\frac{4}{6}$ ○ $\frac{2}{3}$	$\frac{1}{7}$ ○ $\frac{6}{11}$	$\frac{5}{6}$ ○ $\frac{1}{2}$

Name: _____

Make change. You can use \$20, \$10, \$5, \$1, 25¢, 10¢, 5¢, or 1¢.

Pam has \$72.61. She has 6 bills and 7 coins. How?

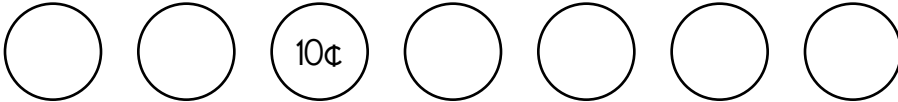

Bill has \$87.14. He has 7 bills and 15 coins. How?

Bill has \$53.31. He has 7 bills and 3 coins. How?

Circle the correctly spelled words.
celebration, capeble, available

What is the homophone of this word?
deer



Name: _____

Make change. You can use \$20, \$10, \$5, \$1, 25¢, 10¢, 5¢, or 1¢.

Pam has \$96.11. She has 9 bills and 10 coins. How?

		\$10		
--	--	------	--	--

--	--	--	--

									1¢
--	--	--	--	--	--	--	--	--	----

Pam has \$6.21. She has 2 bills and 15 coins. How?

Pam has \$15.61. She has 3 bills and 6 coins. How?

Bill has \$60.82. He has 4 bills and 7 coins. How?

Name: _____

Find 2 equations hidden in each box. Good luck!

6 x 4 30 36 12
14 15 18
2 x 6 5 1 + 1
8 x 8 40 13 5 x 6 6

Write 2 equations: _____

42 49 35 16
9 x 9 9 x 3 4 x 7
7 x 3 2 28
2 x 5 5 x 1 81 48 14

Write 2 equations: _____

17 13 4 x 4 9 x 9 2 x 5
7 x 6 24 2 x 7 8
64 15 8 x 3 36
1 81 4

Write 2 equations: _____

Name: _____

Find 2 equations hidden in each box. Good luck!

7 x 7
36
6 x 6
5 x 5
49
2
4 x 3
40
5 x 2
8
6
18
7 x 6

Write 2 equations: _____

4 x 2
6 x 6
63
7 x 5
10
4
81
0
1
9 x 5
4 + 2
6 x 9
9 x 7
24
27
6
7 x 7

Write 2 equations: _____

3
9
2 + 4
3 x 6
0 + 3
32
4 x 8
8 x 0
11
4
3 + 2
7 x 9
24
1 + 1
10
7 x 5

Write 2 equations: _____

Name: _____

playful p l u g p l a y f u l l l l p l a f u l

trapezoid n t r a p a z i o d t r a p e z o i d b

posterior p o s t e r i o p o s t e r i o r r m t

faithful f h f a i t h f u l f i a t f u l f h f

mechanics p m e c h a n i c s n h a x s w n s i m

isolate a x i i s s u h l a y t i s o l a t e q

whose i m v o w h o e s t h l w w h o s e e w

posterity p o s t e r i t y p r o s t e r i t y t

scarecrow s c o d c e s s c a r e c r o w w c i o

challenging i e c h a l l e n g i n g e m g n h n g

ailment a w l a i l m e n t g i a i l e m e n t

dissect t j s c y d i s s e c t d u s s u c t k

fifth x j f i t h o q f i f t h i f f a t w b

above w a a o b v e a b o v e e v h e b c j i

detest t d n d v s e t e s t e t d e t e s t e

munched s d c c h a m u n c h e d m u c h e d n

intersect i n t e r s e s t i n t e r s e c t s e

wonderful w o n d e r f u l w o n d e r f u l l m

ardent t x g a r d e n t g f a r d e n t r a o

desire k l q e d i s i r e r h i r d e s i r e

enthusiastic e n t h u s i a s t i c o a s z c h t k

fever j a c v f e v e r z k f e a v e r w i v

exuberant z x e e x u b e r a n t o a e e t x a t

trees i e t t r e e s s u v t r e e s e e e e

ornament t a b t x a o r n a m e n t m k a c z n

Name: _____

The vowels are missing in the word search.
Fill in the missing vowels and circle the words.

P S T R T Y **F**
 P K C R D N T **E**
 M D S S C T **V**
 S D F F T H R **E**
 T S L T **R**
 S W H S
 R N T R S
 R B V
 H P F L
 R D T S T N

TREES • POSTERIOR • ISOLATE
 WHOSE • FEVER • ABOVE • DESIRE
 FIFTH • ARDENT • DISSECT
 POSTERITY • DETEST • HOPEFUL

T W H O S E F L L A A I B I N
 L C S E P P A U U R I T C S O
 I I F I O O I F F D L C T C I
 E T E N S S T Y E E M E R A T
 X S V T T T H A P N E S E R C
 U A E E E E F L O T N S E E E
 B I R R R R U P H N T I S C S
 E S N S I I L D W P I D O R R
 R U M E T O E V O B A E S O E
 A H I C Y R O N C L H S E W T
 N T N T T O F I F T H I U B N
 T N I S O L A T E N T R E D I
 L E O E T T S E T E D E D E E

DISSECT • TREES • ARDENT
 INTERSECT • FEVER • ABOVE
 AILMENT • FIFTH • FAITHFUL • DESIRE
 POSTERIOR • ISOLATE • WHOSE
 DETEST • HOPEFUL • ENTHUSIASTIC
 EXUBERANT • INTERSECTION
 POSTERITY • SCARECROW • PLAYFUL

If $Q + Q = 8$, then what does Q equal?

$$\begin{array}{r} 21 \\ 55 \\ + 11 \\ \hline \end{array}$$

$$\begin{array}{r} 11 \\ 50 \\ + 28 \\ \hline \end{array}$$

$$\begin{array}{r} 10 \\ \times 5 \\ \hline \end{array}$$

$$\begin{array}{r} 1 \\ \times 7 \\ \hline \end{array}$$

What is the area of a rectangle that measures 4 cm by 6 cm?

$$\begin{array}{r} 2 \\ \times 12 \\ \hline \end{array}$$

$$\begin{array}{r} 5 \\ \times 1 \\ \hline \end{array}$$

Insert punctuation marks into this sentence.
 Ella, Abby said, will you come to my party on Friday?

How many days are in April?



Name: _____

DETEST • MUNCHED • ARDENT • DISSECT • ISOLATE • EXUBERANT
INTERSECT • ABOVE • GARMENT

Write each word into the puzzle.

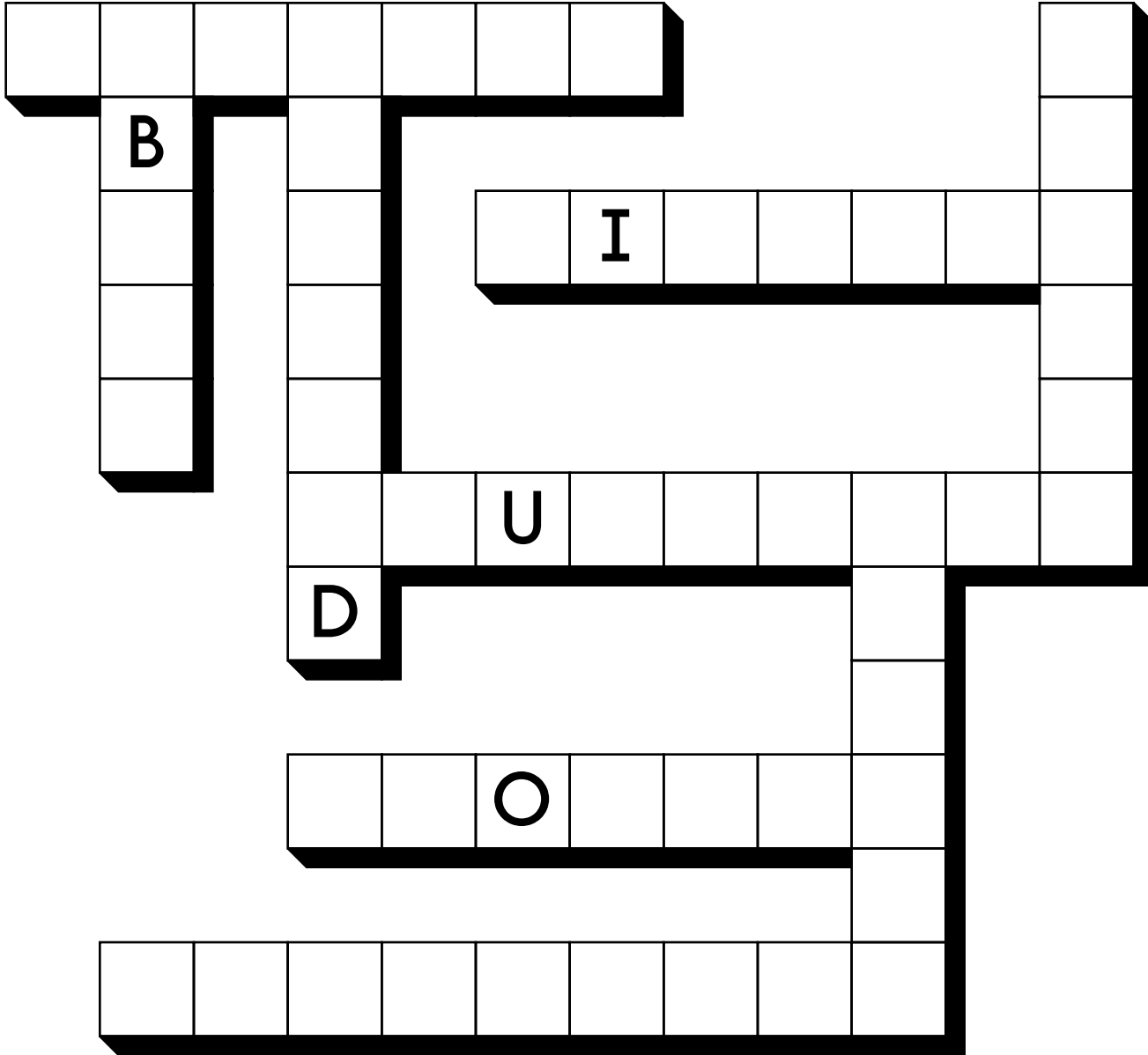

Circle the pronoun(s) in the sentence.

We will be there, but we will need to pick up Cheri's sister first.

Circle the correctly spelled word.

I don't mind gym class, but I really don't like how (thirsty/thirstie) it makes me!

Name: _____

Use each word ONCE. Cross off each word after it is used.

ardent • isolate • ailment • posterior • mechanics • detest • fever
intersect • posterity • ornament • perimeter • enthusiastic
intersection • trees • whose • wonderful • faithful • garment
scarecrow

These words have the long e sound
like in baby.

o s t

f e

These words have
"ment" in them.

m e n t

These words have "te" in
them.

t e

These words have "inter" in them.

i n t e r

Fit the rest of the words into these shapes.

□ □ □ □ e □ □ □ □ □

□ □ □ □ □ e r □ □ □ □ □

□ □ □ □ □ □ □ □ □ □ □

□ □ □ □ □ □ □ □ □ □ □ □ □

□ □ □ □ □ □ □ □ □ □ □ □ □

□ □ □ □ □ □ □ □ □ □ □

Name: _____

You have decided to run for class president—good for you! Write the answers you would give to the following questions during a debate with the other candidate:



Why do you want to be class president?

What is your main goal as president?



What will you do to improve the cafeteria food?

Draw the poster you use in your campaign to get your classmates' votes:



How would you raise money for an awesome class trip, and where do you want the class to go?



Name: _____

detest • dissect • perimeter • hopeful • isolate • mechanics

Each row, column, and box must have all the words from the word list. Write in the missing words.

perimeter					mechanics
isolate		mechanics			
detest	isolate	dissect			
			hopeful	dissect	
			mechanics	isolate	detest

How do you know if a number is divisible by 3? Use this trick.

$$5,127,735 \quad \underline{5} + \underline{1} + \underline{2} + \underline{7} + \underline{7} + \underline{3} + \underline{5} = \boxed{\quad} \boxed{\quad}$$

$$\boxed{\quad} + \boxed{\quad} = \underline{\quad} \quad \text{Is that a multiple of 3? Circle if it is: } 3 \quad 6 \quad 9 \quad 12 \quad 15$$

Circle one: 5,127,735 is divisible by three 5,127,735 is not divisible by three

$$951,948 \quad \underline{\quad} + \underline{\quad} + \underline{\quad} + \underline{\quad} + \underline{\quad} + \underline{\quad} = \boxed{\quad} \boxed{\quad}$$

$$\boxed{\quad} + \boxed{\quad} = \underline{\quad} \quad \text{Is that a multiple of 3? Circle if it is: } 3 \quad 6 \quad 9 \quad 12 \quad 15$$

Circle one: 951,948 is divisible by three 951,948 is not divisible by three

Round the number to the
place value of the BIG number.33**3**,167,253
_____If you add 9 to me, the sum is
80. What number am I?
_____word root **enni** can mean **year****bicentennial, centennial, perennial**

Name: _____

Use each of the blocks to spell four words.
Hint: Use the words isolate and hunched.

1.					H		
2.					A	T	
3.							
4.							

Draw one line to find two words in each puzzle. The bold letters start each word.
You can move left, right, up, or down. Write the two words that you find.

S I K Y J M J V E R B D U U E U D E A R B X I R R A O E A C A P D T B N I D V S E N Y M I A I Q K V I A H F S I Z O J B E E H G	K C Z O R E N Q O P R E I E X R G M O I E B H N J Q J E G R E E I M U D E T F S P D A C F E E V A V H O S C R E W C U C F C Y E	I V C N A R W Q E U C V F U K U N J E U I F A I J U I O F A K E T A X Y T T O V F H Q A H A B M Y O O E S I X C A O P K G A I E
_____	_____	_____
_____	_____	_____

What are 27 hundreds equal to?

You ask Rose for the time.
She says it is four minutes past four. Write the time on your digital clock:

:

5 $\overline{)10}$

Name: _____

Write the hidden word. Start at one letter and then move either left or right. Continue in same direction.

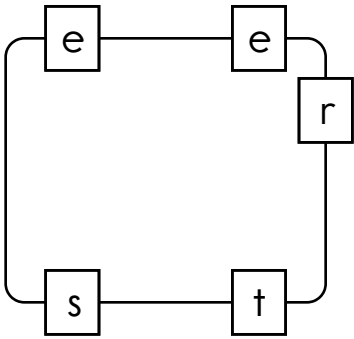

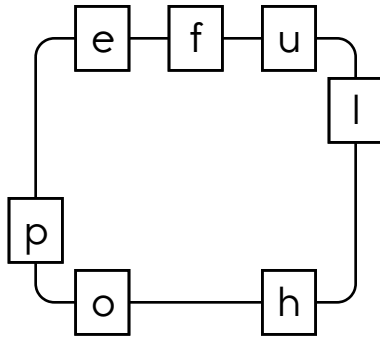

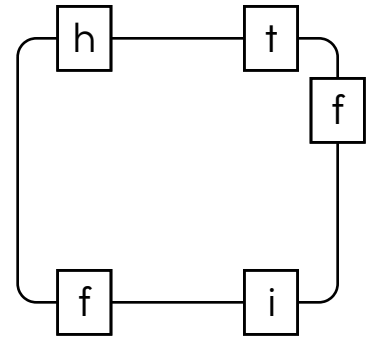

Circle the words.

fifthtrapezoiddissectardentmechanicsgarmentdesire
 desireardentscarecrowtrapezoiddissectgarmentfifth
 garmentfifthscarecrowmechanicstrapezoidintersect

Try to spell some words.

lle • pe • ~~x~~ec • ~~x~~a • ri • ay • ent • re • ~~x~~i • ga • rm
 er • pl • si • cha • de • ful • ~~x~~s • met • ing • ng

mechanics _____ _____ _____

Reduce $\frac{15}{20}$ to its lowest terms.

Reduce $\frac{18}{27}$ to its lowest terms.

Reduce $\frac{16}{40}$ to its lowest terms.

word root **in** can mean **not or in** **indescribable, innovate, inspection**

Name: _____

Which way does each word go? Write the word.

<p>1. ↘ SLAVE ↓ SEASHORES ← SOCK → SEIZE</p>	<p>1. ↓ UNWILLING 2. NOISY → USED NEST ↘ UNTIE ← NAVY ← UGLY</p>																																																																																																																																								
<table border="1" style="margin: auto; border-collapse: collapse;"> <tr><td>K</td><td>C</td><td>O</td><td>¹S</td><td></td><td></td><td></td><td></td></tr> <tr><td style="background: repeating-linear-gradient(45deg, transparent, transparent 2px, black 2px, black 4px);"></td><td style="background: repeating-linear-gradient(45deg, transparent, transparent 2px, black 2px, black 4px);"></td><td style="background: repeating-linear-gradient(45deg, transparent, transparent 2px, black 2px, black 4px);"></td><td></td><td style="background: repeating-linear-gradient(45deg, transparent, transparent 2px, black 2px, black 4px);"></td><td style="background: repeating-linear-gradient(45deg, transparent, transparent 2px, black 2px, black 4px);"></td><td style="background: repeating-linear-gradient(45deg, transparent, transparent 2px, black 2px, black 4px);"></td><td style="background: repeating-linear-gradient(45deg, transparent, transparent 2px, black 2px, black 4px);"></td></tr> <tr><td style="background: repeating-linear-gradient(45deg, transparent, transparent 2px, black 2px, black 4px);"></td><td style="background: repeating-linear-gradient(45deg, transparent, transparent 2px, black 2px, black 4px);"></td><td style="background: repeating-linear-gradient(45deg, transparent, transparent 2px, black 2px, black 4px);"></td><td></td><td style="background: repeating-linear-gradient(45deg, transparent, transparent 2px, black 2px, black 4px);"></td><td style="background: repeating-linear-gradient(45deg, transparent, transparent 2px, black 2px, black 4px);"></td><td style="background: repeating-linear-gradient(45deg, transparent, transparent 2px, black 2px, black 4px);"></td><td style="background: repeating-linear-gradient(45deg, transparent, transparent 2px, black 2px, black 4px);"></td></tr> <tr><td style="background: repeating-linear-gradient(45deg, transparent, transparent 2px, black 2px, black 4px);"></td><td style="background: repeating-linear-gradient(45deg, transparent, transparent 2px, black 2px, black 4px);"></td><td style="background: repeating-linear-gradient(45deg, transparent, transparent 2px, black 2px, black 4px);"></td><td></td><td style="background: repeating-linear-gradient(45deg, transparent, transparent 2px, black 2px, black 4px);"></td><td style="background: repeating-linear-gradient(45deg, transparent, transparent 2px, black 2px, black 4px);"></td><td style="background: repeating-linear-gradient(45deg, transparent, transparent 2px, black 2px, black 4px);"></td><td style="background: repeating-linear-gradient(45deg, transparent, transparent 2px, black 2px, black 4px);"></td></tr> <tr><td style="background: repeating-linear-gradient(45deg, transparent, transparent 2px, black 2px, black 4px);"></td><td style="background: repeating-linear-gradient(45deg, transparent, transparent 2px, black 2px, black 4px);"></td><td style="background: repeating-linear-gradient(45deg, transparent, transparent 2px, black 2px, black 4px);"></td><td></td><td style="background: repeating-linear-gradient(45deg, transparent, transparent 2px, black 2px, black 4px);"></td><td style="background: repeating-linear-gradient(45deg, transparent, transparent 2px, black 2px, black 4px);"></td><td style="background: repeating-linear-gradient(45deg, transparent, transparent 2px, black 2px, black 4px);"></td><td style="background: repeating-linear-gradient(45deg, transparent, transparent 2px, black 2px, black 4px);"></td></tr> <tr><td style="background: repeating-linear-gradient(45deg, transparent, transparent 2px, black 2px, black 4px);"></td><td style="background: repeating-linear-gradient(45deg, transparent, transparent 2px, black 2px, black 4px);"></td><td style="background: repeating-linear-gradient(45deg, transparent, transparent 2px, black 2px, black 4px);"></td><td></td><td style="background: repeating-linear-gradient(45deg, transparent, transparent 2px, black 2px, black 4px);"></td><td style="background: repeating-linear-gradient(45deg, transparent, transparent 2px, black 2px, black 4px);"></td><td style="background: repeating-linear-gradient(45deg, transparent, transparent 2px, black 2px, black 4px);"></td><td style="background: repeating-linear-gradient(45deg, transparent, transparent 2px, black 2px, black 4px);"></td></tr> <tr><td style="background: repeating-linear-gradient(45deg, transparent, transparent 2px, black 2px, black 4px);"></td><td style="background: repeating-linear-gradient(45deg, transparent, transparent 2px, black 2px, black 4px);"></td><td style="background: repeating-linear-gradient(45deg, transparent, transparent 2px, black 2px, black 4px);"></td><td></td><td style="background: repeating-linear-gradient(45deg, transparent, transparent 2px, black 2px, black 4px);"></td><td style="background: repeating-linear-gradient(45deg, transparent, transparent 2px, black 2px, black 4px);"></td><td style="background: repeating-linear-gradient(45deg, transparent, transparent 2px, black 2px, black 4px);"></td><td style="background: repeating-linear-gradient(45deg, transparent, transparent 2px, black 2px, black 4px);"></td></tr> <tr><td style="background: repeating-linear-gradient(45deg, transparent, transparent 2px, black 2px, black 4px);"></td><td style="background: repeating-linear-gradient(45deg, transparent, transparent 2px, black 2px, black 4px);"></td><td style="background: repeating-linear-gradient(45deg, transparent, transparent 2px, black 2px, black 4px);"></td><td></td><td style="background: repeating-linear-gradient(45deg, transparent, transparent 2px, black 2px, black 4px);"></td><td style="background: repeating-linear-gradient(45deg, transparent, transparent 2px, black 2px, black 4px);"></td><td style="background: repeating-linear-gradient(45deg, transparent, transparent 2px, black 2px, black 4px);"></td><td style="background: repeating-linear-gradient(45deg, transparent, transparent 2px, black 2px, black 4px);"></td></tr> </table>	K	C	O	¹ S																																																													<table border="1" style="margin: auto; border-collapse: collapse;"> <tr><td></td><td></td><td></td><td>¹U</td><td></td><td></td><td style="background: repeating-linear-gradient(45deg, transparent, transparent 2px, black 2px, black 4px);"></td><td style="background: repeating-linear-gradient(45deg, transparent, transparent 2px, black 2px, black 4px);"></td></tr> <tr><td>Y</td><td>V</td><td>A</td><td>²N</td><td></td><td style="background: repeating-linear-gradient(45deg, transparent, transparent 2px, black 2px, black 4px);"></td><td style="background: repeating-linear-gradient(45deg, transparent, transparent 2px, black 2px, black 4px);"></td><td style="background: repeating-linear-gradient(45deg, transparent, transparent 2px, black 2px, black 4px);"></td></tr> <tr><td style="background: repeating-linear-gradient(45deg, transparent, transparent 2px, black 2px, black 4px);"></td><td style="background: repeating-linear-gradient(45deg, transparent, transparent 2px, black 2px, black 4px);"></td><td></td><td>W</td><td></td><td style="background: repeating-linear-gradient(45deg, transparent, transparent 2px, black 2px, black 4px);"></td><td style="background: repeating-linear-gradient(45deg, transparent, transparent 2px, black 2px, black 4px);"></td><td style="background: repeating-linear-gradient(45deg, transparent, transparent 2px, black 2px, black 4px);"></td></tr> <tr><td style="background: repeating-linear-gradient(45deg, transparent, transparent 2px, black 2px, black 4px);"></td><td style="background: repeating-linear-gradient(45deg, transparent, transparent 2px, black 2px, black 4px);"></td><td style="background: repeating-linear-gradient(45deg, transparent, transparent 2px, black 2px, black 4px);"></td><td>I</td><td></td><td style="background: repeating-linear-gradient(45deg, transparent, transparent 2px, black 2px, black 4px);"></td><td style="background: repeating-linear-gradient(45deg, transparent, transparent 2px, black 2px, black 4px);"></td><td style="background: repeating-linear-gradient(45deg, transparent, transparent 2px, black 2px, black 4px);"></td></tr> <tr><td style="background: repeating-linear-gradient(45deg, transparent, transparent 2px, black 2px, black 4px);"></td><td style="background: repeating-linear-gradient(45deg, transparent, transparent 2px, black 2px, black 4px);"></td><td style="background: repeating-linear-gradient(45deg, transparent, transparent 2px, black 2px, black 4px);"></td><td>L</td><td></td><td style="background: repeating-linear-gradient(45deg, transparent, transparent 2px, black 2px, black 4px);"></td><td style="background: repeating-linear-gradient(45deg, transparent, transparent 2px, black 2px, black 4px);"></td><td style="background: repeating-linear-gradient(45deg, transparent, transparent 2px, black 2px, black 4px);"></td></tr> <tr><td style="background: repeating-linear-gradient(45deg, transparent, transparent 2px, black 2px, black 4px);"></td><td style="background: repeating-linear-gradient(45deg, transparent, transparent 2px, black 2px, black 4px);"></td><td style="background: repeating-linear-gradient(45deg, transparent, transparent 2px, black 2px, black 4px);"></td><td>L</td><td></td><td style="background: repeating-linear-gradient(45deg, transparent, transparent 2px, black 2px, black 4px);"></td><td style="background: repeating-linear-gradient(45deg, transparent, transparent 2px, black 2px, black 4px);"></td><td style="background: repeating-linear-gradient(45deg, transparent, transparent 2px, black 2px, black 4px);"></td></tr> <tr><td style="background: repeating-linear-gradient(45deg, transparent, transparent 2px, black 2px, black 4px);"></td><td style="background: repeating-linear-gradient(45deg, transparent, transparent 2px, black 2px, black 4px);"></td><td style="background: repeating-linear-gradient(45deg, transparent, transparent 2px, black 2px, black 4px);"></td><td>I</td><td></td><td style="background: repeating-linear-gradient(45deg, transparent, transparent 2px, black 2px, black 4px);"></td><td style="background: repeating-linear-gradient(45deg, transparent, transparent 2px, black 2px, black 4px);"></td><td style="background: repeating-linear-gradient(45deg, transparent, transparent 2px, black 2px, black 4px);"></td></tr> <tr><td style="background: repeating-linear-gradient(45deg, transparent, transparent 2px, black 2px, black 4px);"></td><td style="background: repeating-linear-gradient(45deg, transparent, transparent 2px, black 2px, black 4px);"></td><td style="background: repeating-linear-gradient(45deg, transparent, transparent 2px, black 2px, black 4px);"></td><td>N</td><td></td><td style="background: repeating-linear-gradient(45deg, transparent, transparent 2px, black 2px, black 4px);"></td><td style="background: repeating-linear-gradient(45deg, transparent, transparent 2px, black 2px, black 4px);"></td><td style="background: repeating-linear-gradient(45deg, transparent, transparent 2px, black 2px, black 4px);"></td></tr> <tr><td style="background: repeating-linear-gradient(45deg, transparent, transparent 2px, black 2px, black 4px);"></td><td style="background: repeating-linear-gradient(45deg, transparent, transparent 2px, black 2px, black 4px);"></td><td style="background: repeating-linear-gradient(45deg, transparent, transparent 2px, black 2px, black 4px);"></td><td>G</td><td></td><td style="background: repeating-linear-gradient(45deg, transparent, transparent 2px, black 2px, black 4px);"></td><td style="background: repeating-linear-gradient(45deg, transparent, transparent 2px, black 2px, black 4px);"></td><td style="background: repeating-linear-gradient(45deg, transparent, transparent 2px, black 2px, black 4px);"></td></tr> </table>				¹ U					Y	V	A	² N								W								I								L								L								I								N								G				
K	C	O	¹ S																																																																																																																																						
			¹ U																																																																																																																																						
Y	V	A	² N																																																																																																																																						
			W																																																																																																																																						
			I																																																																																																																																						
			L																																																																																																																																						
			L																																																																																																																																						
			I																																																																																																																																						
			N																																																																																																																																						
			G																																																																																																																																						

The perimeter is _____.

Write the length in centimeters.

Color in $\frac{1}{2}$ of the rectangle.

What temperature is seven degrees below freezing in Fahrenheit?

Do you use A.M. or P.M. to write the time you eat dinner?



Name: _____

1. COACH
CLIFF
CARE
→ CARRY
CRANE

2. ARMIES
→ ALERT

3. ROD
↓ RIFLE
REEF

4. TIE
TOY
TAX
TOOTHBRUSHES
↓ TWIST
TON

5. FOUL
↖ FED
FEUD
FEET

6. ↖ OF
OFF
OAR

7. ← HID
HE
HOIST
HUG

8. PAT
→ PRAY
PINE
PESTS
POUR
PEST

H	C	A	O	¹ C					
					² A	L	E	R	T
						³ R			
		⁴ T	O	N			E		
						⁵		E	
							⁶		F
			E						
		⁷ H							
						⁸			

How do you know if a number is divisible by 3? Use this trick.

519,240 5 + 1 + 9 + 2 + 4 + 0 =

+ = ____ Is that a multiple of 3? Circle if it is: 3 6 9 12 15

Circle one: 519,240 is divisible by three 519,240 is not divisible by three

3,567,309 ____ + ____ + ____ + ____ + ____ + ____ + ____ =

+ = ____ Is that a multiple of 3? Circle if it is: 3 6 9 12 15

Circle one: 3,567,309 is divisible by three 3,567,309 is not divisible by three

Name: _____

Circle words to the RIGHT or DOWN. Every letter is used exactly ONCE.

Y O U P O S T E R I T Y W H O S E
 A M P D I C H A L L E N G I N G
 I U L I S I N T E R S E C T I O N
 L N A S O T W R W O N D E R F U L
 M C Y S L O A U P O S T E R I O R
 E H F E A Y S B O R N A M E N T
 N E U C T D E T E S T D E S I R E
 T D L T E W H Y M E C H A N I C S

Write the words found.

MECHANICS	DESIRE	
_____	_____	_____
_____	_____	_____
_____	_____	_____
_____	_____	_____
_____	_____	_____
_____	_____	_____

What is the value of the BIG digit? 8 8,132,100 _____	If $B + B = 6$, then what does B equal? _____	<input type="radio"/> hiri <input type="radio"/> hire <input type="radio"/> hori <input type="radio"/> hirre
--	---	---

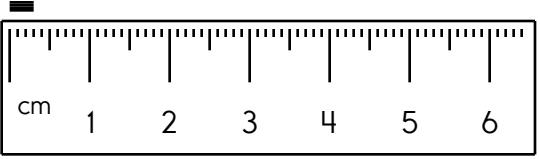
Write the length in millimeters. _____ 	What number is ten thousand more than 4,663? _____	$\begin{array}{r} 97 \\ - 89 \\ \hline \end{array}$
--	---	---



$71 - 8 = \underline{\quad}$	Do parallel lines intersect? _____
------------------------------	---------------------------------------

Name: _____

Max bought a box of 24 chocolate cookies. He paid \$3.74 for the box of cookies. His mother made 24 chocolate raisin cookies. She spent \$1.19 for the ingredients. How much more did Max spend than his mother spent?

Write the length in inches.

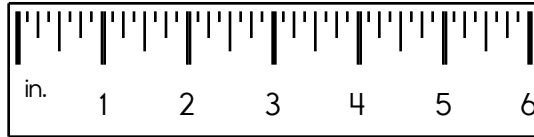

- crompt
- crept
- cript
- cret

How do you know if a number is divisible by 4? Look at the last two digits of the number.

80,834,928

Is divisible by 4? Yes No

If Yes, fill in: ÷ 4 = ____

Circle one: 80,834,928 is divisible by four 80,834,928 is not divisible by four

9,733,365

Is divisible by 4? Yes No

If Yes, fill in: ÷ 4 = ____

Circle one: 9,733,365 is divisible by four 9,733,365 is not divisible by four

There was a big sign in front of the park. It was about buying a car. It was very ugly. You couldn't even see the park entrance! The sign was 22 feet long and 13 feet high. What was the perimeter of the sign?

Write the unshaded part as a decimal.





Which is longer: two feet or twenty-eight inches?

Name: _____

Read the paragraph. Write a topic sentence that describes the paragraph.

My favorite sport is football. I have played football for the past five years. There is nothing better than putting on pads and throwing a football around. My dad is my football coach. He teaches me football plays and strategies. When I am not playing with a team, I am playing football in the backyard with my dad. I have played many different sports, but football is my most favorite sport.

Write a topic sentence for the paragraph: _____

Circle all of the words that are spelled correctly.

nembar	sprin	sqirt	hortea	rent
wooden		roast	troh	
calculate	gihfts	laeder	journal	hyuoz
vegetable		vine	avunooz	
gallons	bihgur	celings	neybar	burst
bachuh		klo	biggir	
piint	heal	krekur	batch	could

$5 \overline{)25}$

$8 \overline{)16}$

$4 \overline{)28}$

$7 \overline{)28}$

$3 \overline{)24}$

$5 \overline{)45}$

Jessica made 60 peanut butter sandwiches. She put them on a plate with 15 sandwiches in each stack. How many stacks did she make?

How many days are in December?
_____Can you think of a five-letter word that has the vowel A in it?

$$\begin{array}{r} 51 \\ 25 \\ + 11 \\ \hline \end{array}$$



Name: _____

Did you know that you don't always have to use the word **damaged** in your writing? Try to use different words for an overused word like **damaged**. It will make your work more fun for others to read.

Circle words to the RIGHT or DOWN. Every letter is used exactly ONCE.

D		D	E	S	T	R	O	Y	E	D			
E	B	M		F	L	A	W	E	D				
I	M	L	U	S	H	A	T	T	E	R	E	D	
M	O	I	E	T	S	S	P	O	I	L	E	D	W
P	L	N	M	I	M						B	R	
A	I	J	I	L	A						R	E	
I	S	U	S	A	S						O	C	
R	H	R	H	T	H						K	K	
E	E	E	E	E	E						E	E	
D	D	D	D	D	D						N	D	

Write the words found.

<u>WRECKED</u>	<u>SHATTERED</u>	_____
_____	_____	_____
_____	_____	_____
_____	_____	_____

Write something using the word **damaged** at least two times.

Now rewrite your boring writing without using the word **damaged**.

I can't wait to read it!

How many words do you think it takes to improve your writing?

Fifty. That's 50! There are about 50 overused words we often use in writing and conversations.

When you find yourself repeating, try something different. It doesn't take much work to sound amazing!

Name: _____

One letter is missing from each word.

E V I D E N C E

N E I G H B O

P A R T E R

I N S R E

D E N O U N C

I P R O V E

These are a little harder with two letters missing.

E B L E

P U S S

H E

S I P E

C O M E T E

T E

P N Y

D N E R

Write your own words!

Name: _____

CH Words

CH makes /ch/ sound

D E M R A H C P E A C H C E A
 A S E H C T A R C S N H H U C
 C L A U N C H E D H C A O C H
 H C H I M N E Y C H O P K A A
 E P H A N I H C H E C K E D S
 C H C U O R G C D H H H D L E
 K D E N R U H C H O O S E S S
 U E K U C H A T S E T C H E S
 P F E T C H S E H C N A R E S
 K C H E A T I N G T H C H U G

COACH • LAUNCHED • GROUCH
 FETCH • CHATS • CHIMNEY
 CHURNED • CHECKUP • CHECKED
 PEACH • ETCHES • CHOOSES • CHIN
 CHOP • SCRATCHES • CHUG
 CHOKED • CHARMED • CHASES
 CHEATING • RANCHES

CH makes /k/ sound

C C A N Y G O L O H C Y S P C
 H C H E M I C A L O O H C S H
 E G L A C I N A H C E M S L R
 M U H L C H R O N I C O C I I
 I O Y G O L O N H C E T H C S
 S T O M A C H S S E A E E H T
 T R H N S E O H C E C M M E E
 R O R C H E S T R A H O E N N
 Y H N H E A D A C H E I C L H
 A E Y S C H O L A R S H I P P

ACHE • MECHANICAL • SCHOLARSHIP
 CHEMICAL • TECHNOLOGY • SCHEME
 CHRONIC • LICHEN • ORCHESTRA
 HEADACHE • CHEMISTRY • SCHOOL
 PSYCHOLOGY • STOMACHS • ECHOES
 CHRISTEN

Does the "CH" in each word have the ch or k sound? Circle the sound that "CH" makes.

teacher	ch k	lichen	ch k	charter	ch k
orchestra	ch k	christening	ch k	melancholy	ch k
technique	ch k	chatting	ch k	pitch	ch k
inched	ch k	bunches	ch k	lunch	ch k
latch	ch k	changing	ch k	school	ch k
stomach	ch k	charted	ch k	watched	ch k
notch	ch k	cherries	ch k	etching	ch k

Name: _____

CH Words

CH Words

slouches • fetch • anchoring • schooling • christen • psychologist
attach • chimney • scholar • bleaching • melancholy • birch

CH makes /k/ sound as in echo	CH makes /ch/ sound as in chalk	not sure
schooling	bleaching	
_____	_____	_____
_____	_____	_____
_____	_____	_____
_____	_____	_____
_____	_____	_____

Help! Some of the CH words from this page and the previous page are written like they sound. Can you figure out the real spelling of these words? Good luck.

luhnch lunch _____

awrkuhstruh _____

tēchur _____

skōlurshihp _____

ihncht _____

chōrtur _____

hEHdāk _____

EHchihz _____

uhtach _____

blēchihNG _____

pihch _____

slouchihz _____

ō kōz → cause

oo choo → chew

ā kāk → cake

ē fēt → feet

ī īs → ice

ō bōt → boat

ū kūt → cute

Name: _____

CH Words

palyers • players • they • thrrree • ~~believed~~ • eahc • asummed
 encouraged • beleved • three • palyed • be • inn • each
 assumed • bee • plaing • cheered • encourged • bue • played
 in • playing

The soccer team had been _____ together for three years. They'd
 _____ seasons in their city league and
 traveled all over the state to compete _____ different tournaments.
 Coach Jackson _____ believed _____ that _____ of his players
 had great talent. He _____ them on and _____
 them to _____ the best _____ and students
 _____ could be.

garage • advance • heartwarming • much • advanc • ~~see~~ • to
 sae • showed • too • sea • showwed • growht • ttoo • growth

Each mark on the doorframe _____ the children's
 _____. Mr. Dockers had marked his children's height on the
 doorframe to the _____ on the first day of school each year. It was
 a quick and _____ way _____
 _____ see _____ how _____ they had grown from one
 grade to the next.



It's NO PREP at edHelper.

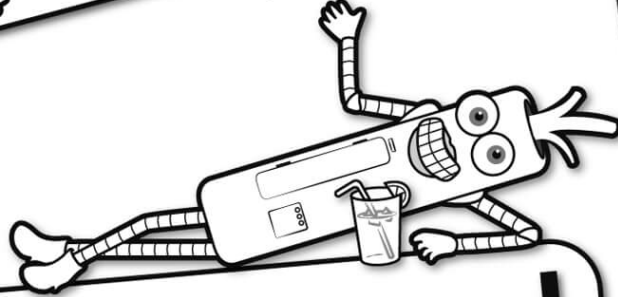

edHelper.com!

More history!

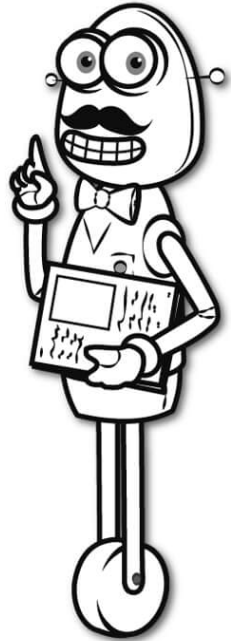

only \$19.99 per year

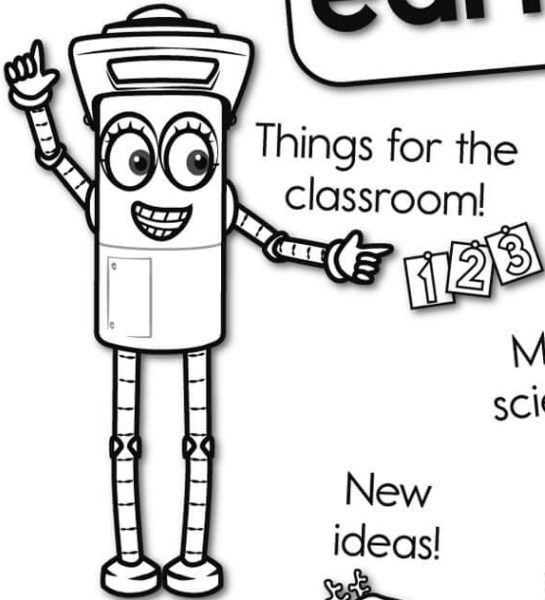

Things for the classroom!



New ideas!



More science!

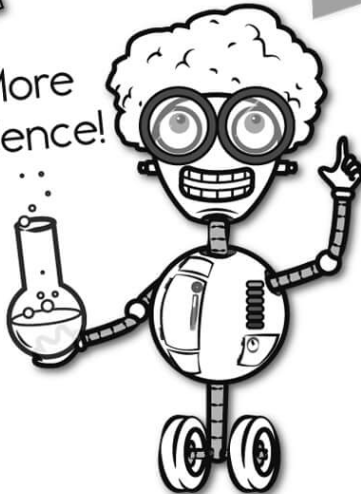

More puzzles!

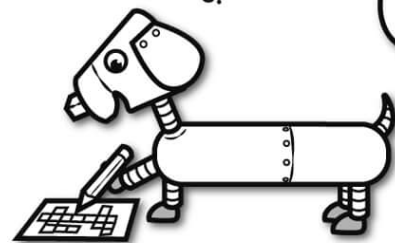

Take The Boring Out Of Homework!

Easy to
print!

edHelper

Weekly K-6 "Take It Home" Books

Kids want choices
for homework.
"Take It Home" books
have fun graphics and
challenging puzzles and
problems for older kids.

"Dr. Programmer"
challenges kids..

Homework
will never be
the same!

edHelper.com

